

SECTION A-A

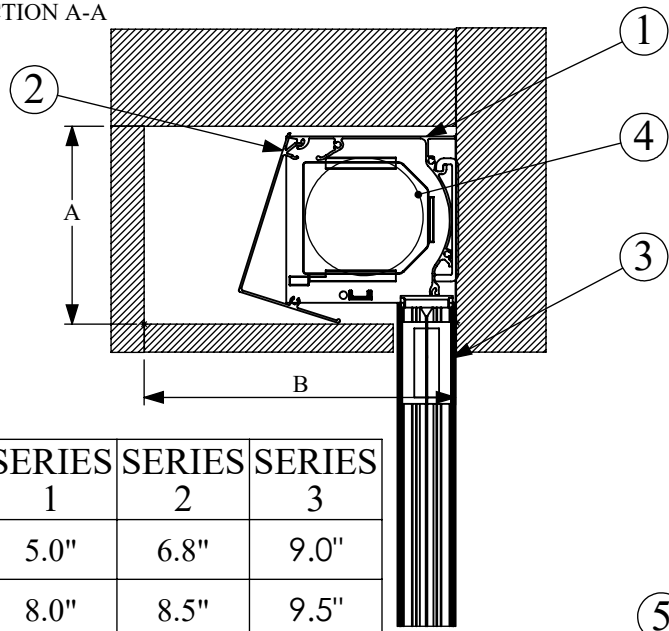

	SERIES 1	SERIES 2	SERIES 3
A	5.0"	6.8"	9.0"
B	8.0"	8.5"	9.5"

NOTE:
ADD (2.125") FOR THE CROSSBAR
TO BE INCLUDED IN THE BOX

SECTION B-B

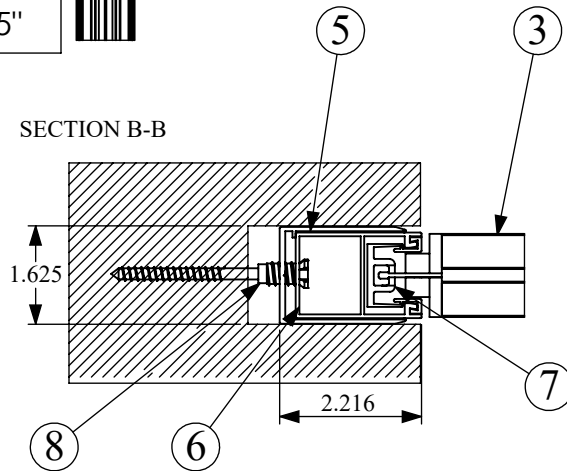

MOTOR	VOLTS	AMPS	Hz	Torque IN/LBS	RPM
530	120 Vac	2.4	60	265	21

NOTE:
Available in Motor or Spring

A ORDER WIDTH IS HOUSING CAP TO HOUSING CAP
(OUTSIDE EDGE OF RAIL TO OUTSIDE EDGE OF RAIL)

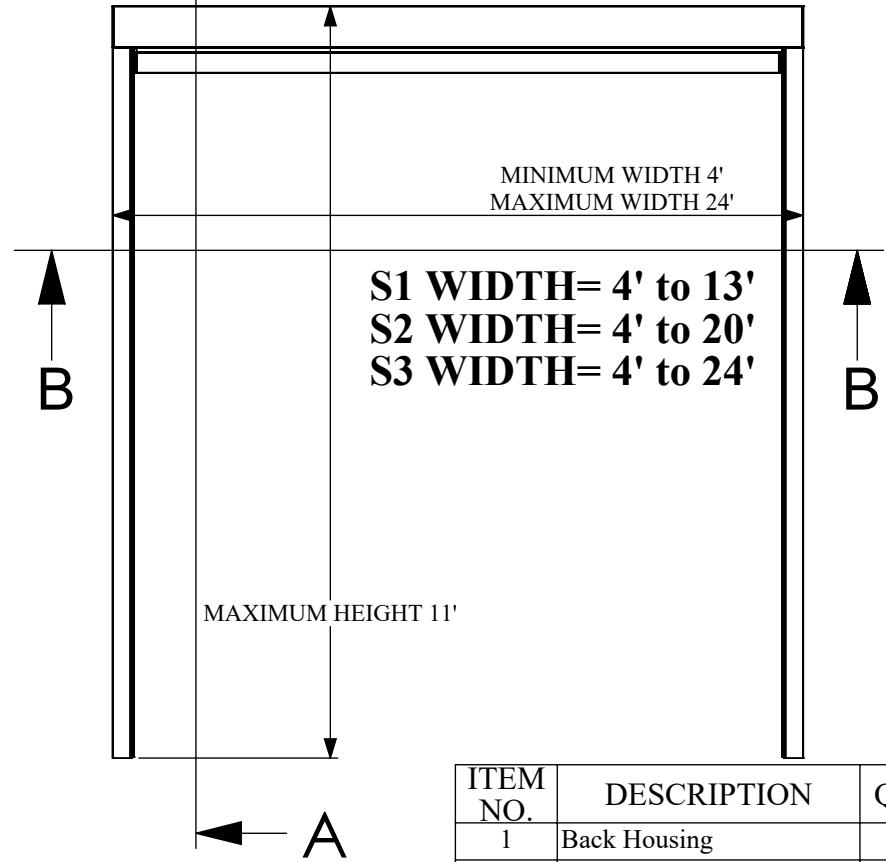

ITEM NO.	DESCRIPTION	QTY.
1	Back Housing	1
2	Front Cover	1
3	Crossbar	1
4	Roll Tube	1
5	Outside Rail (C-Channel)	1
6	Zip Guide Rail	4
7	Zipper Retainer	2
8	Adjustable Recessed Screw	2

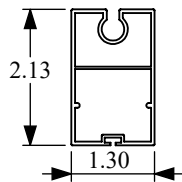

Crossbar

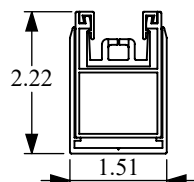

Rail

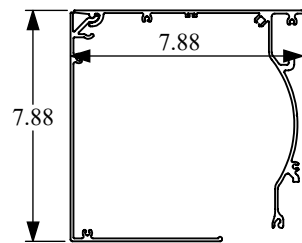

Series 3 Housing

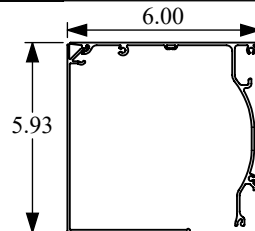

Series 2 Housing

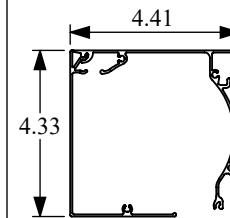

Series 1 Housing

STOETT
INDUSTRIES

PANORAMA ULTRA
RECESSED MOUNT

SIZE A	DWG. NO.	REV.
SCALE:1:50	WEIGHT:	SHEET 1 OF 1